



State of Texas  
ITS Architectures and Deployment Plans

# Atlanta Region

---

## Executive Summary

*Prepared by:*



ConSysTec Corp

**November 7, 2003**

068510007

Copyright © 2003 by Texas Department of Transportation. All rights reserved.



## TABLE OF CONTENTS

### EXECUTIVE SUMMARY

<b>PROJECT APPROACH.....</b>	<b>1</b>
<b>OVERVIEW OF THE ATLANTA REGION .....</b>	<b>2</b>
<b>ATLANTA REGION STAKEHOLDERS .....</b>	<b>4</b>
<b>ATLANTA REGIONAL ITS ARCHITECTURE.....</b>	<b>5</b>
<b>Inventory and Needs in the Region.....</b>	<b>5</b>
<b>Market Packages .....</b>	<b>7</b>
<b>Interconnects, Interfaces, and Standards.....</b>	<b>7</b>
<b>Operational Concept and Scenarios .....</b>	<b>11</b>
<b>Agreements .....</b>	<b>12</b>
<b>ITS Architecture Documentation.....</b>	<b>12</b>
<b>ATLANTA REGIONAL ITS DEPLOYMENT PLAN.....</b>	<b>13</b>
<b>Prioritized Market Packages.....</b>	<b>13</b>
<b>ITS Project Recommendations for the Atlanta Region .....</b>	<b>15</b>
<b>MAINTAINING THE REGIONAL ITS ARCHITECTURE AND DEPLOYMENT PLAN.....</b>	<b>19</b>
<b>MEMORANDUM OF UNDERSTANDING .....</b>	<b>20</b>



## TABLE OF CONTENTS

### EXECUTIVE SUMMARY

## LIST OF FIGURES

Figure 1 – Atlanta Regional ITS Architecture and Deployment Plan Development Process.....	1
Figure 2 – Atlanta Region.....	3
Figure 3 – Atlanta Regional System Interconnect Diagram .....	8
Figure 4 – TxDOT Atlanta District TMC Network Surveillance Customized Market Package .....	9
Figure 5 – TxDOT Atlanta District Traffic Signals Interfaces .....	10
Figure 6 – TxDOT Atlanta District TMC/Office to Other Texas Region TMCs Architecture Flows.....	11

## LIST OF TABLES

Table 1 – Atlanta Region: Summary of ITS Needs .....	6
Table 2 – Summary of Prioritized Market Packages for the Atlanta Region.....	14
Table 3 – Recommended ITS Projects for the Atlanta Region.....	16

## PROJECT APPROACH

The Federal Highway Administration (FHWA) issued a final rule to implement Section 5206(e) of the Transportation Equity Act for the 21st Century (TEA-21) in January of 2001. This final rule requires that Intelligent Transportation System (ITS) projects funded through the Highway Trust Fund conform to the National ITS Architecture and applicable standards. FHWA has further established a deadline of April 2005 for regions to have an ITS architecture in place.

To meet these requirements and ensure future federal funding eligibility for ITS, the Texas Department of Transportation (TxDOT) initiated the development of regional ITS architectures and deployment plans throughout the State of Texas. There are several metropolitan areas in the state that already have ITS architectures in place or under development. The focus of the State of Texas Regional ITS Architectures and Deployment Plans program is to develop architectures in those areas outside of the Austin, Houston, Dallas, Fort Worth, and San Antonio Regions. TxDOT expanded upon the ITS architecture requirements outlined in the FHWA Final Rule, and included an ITS deployment plan as part of the Regional efforts. The regional ITS architecture provides a framework for ITS systems, services, integration, and interoperability, and the regional ITS deployment plan identifies specific projects and timeframes for ITS implementation to support the vision developed by stakeholders in the architecture.

TxDOT's process for developing the regional ITS architectures and deployment plans followed a consensus-based approach to meeting the requirements in the FHWA Final Rule and supporting guidelines. This process was further tailored to meet the specific multi-agency needs of these Regional plans, and was structured around stakeholder input and involvement. The addition of an ITS deployment plan provides for a tangible road map for regional ITS deployment and integration. **Figure 1** shows the development process for each of the State of Texas Regional ITS Architectures and Deployment Plans.

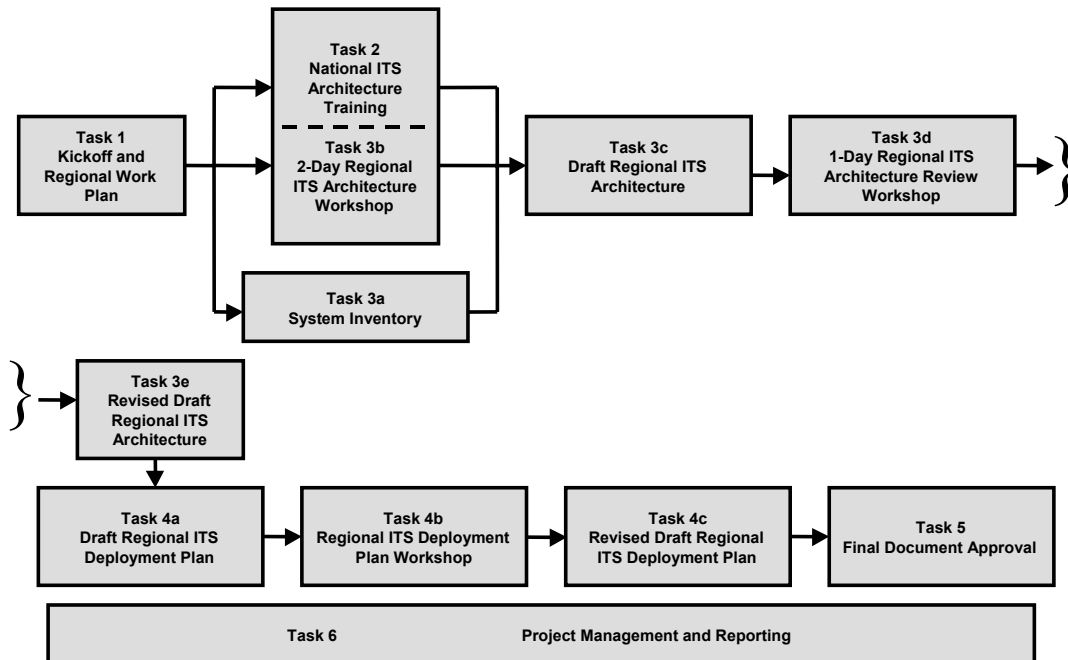

**Figure 1 – Atlanta Regional ITS Architecture and Deployment Plan Development Process**

## OVERVIEW OF THE ATLANTA REGION

The Atlanta Region is bordered by the TxDOT Lufkin District to the southeast, the TxDOT Tyler District to the southwest, Louisiana to the east, Oklahoma to the north, Arkansas to the northeast and the TxDOT Paris District to the northwest. For the Atlanta Regional ITS Architecture and Deployment Plan, the study area included all nine counties that comprise the TxDOT Atlanta District as well as Miller and Little River counties in Arkansas, the City of Texarkana, Arkansas and Caddo Parish, Louisiana. **Figure 2** illustrates the Regional boundaries.

The Atlanta Region contains several key transportation corridors. I-20 is an east-west, four-lane divided interstate highway. I-20 extends from South Carolina in the east to California in the west. I-30 is also an east-west, four lane divided interstate highway in the Region. This facility runs from Little Rock, Arkansas to Dallas, Texas. Other primary facilities in the Atlanta Region include US 59, US 79, US 80, US 82, US 259, and US 271. Transit services in the Region are available and are predominantly on-demand, although there are a few fixed-route schedules in Texarkana.

Within the Atlanta Region there are currently several ITS programs that are underway or are planned for deployment. The TxDOT Atlanta District Office has video detection at several intersections in the Region and a CCTV camera in place in one location prone to heavy fog conditions to monitor fog levels and provide a decision making tool for determining when road closures are necessitated. TxDOT also has an RWIS station in the Region collecting road weather data and 15 Smart Curves. The Texas Department of Public Safety is utilizing a computer aided dispatch (CAD) system in the Atlanta Region. The Marshall Fire and Police Departments are also using a limited CAD system.

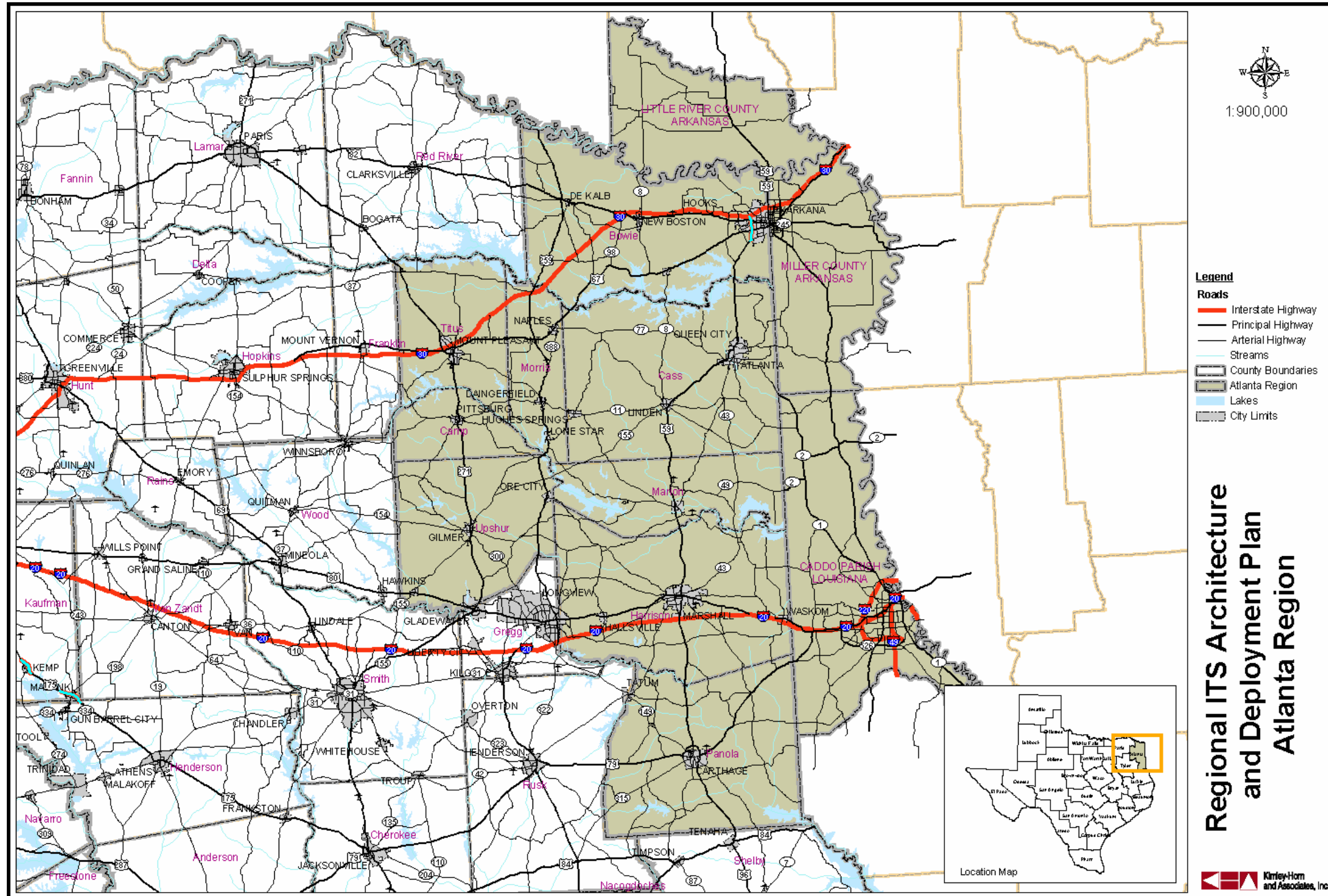

Figure 2 – Atlanta Region



## ATLANTA REGION STAKEHOLDERS

Involving a range of perspectives in the development of a regional ITS architecture and deployment plan, and obtaining consensus on the vision and recommendations are key components to the process. Stakeholders from throughout the Atlanta Region and neighboring Regions participated in the development of the Atlanta Regional ITS Architecture and Deployment Plan. Key participants included representatives from TxDOT Atlanta, cities, the Texarkana Metropolitan Planning Organization (MPO), and transit agencies. These stakeholders provided input and review at key steps in the development process, including a project kick-off meeting, architecture development and review workshops, a deployment plan workshop, and review of the final project documentation.

Atlanta Region stakeholders included:

- Arkansas State Highway and Transportation Department;
- Ark-Tex Council of Governments;
- ATCOG 911 Services;
- City of Atlanta;
- City of Texarkana, Texas;
- City of Texarkana, Arkansas;
- Texarkana MPO;
- City of Marshall;
- Department of Public Safety;
- Federal Highway Administration;
- Louisiana Department of Transportation and Development;
- Texarkana Urban Transit District;
- TxDOT Atlanta District; and
- TxDOT Traffic Operations Division (Austin).



## ATLANTA REGIONAL ITS ARCHITECTURE

The process for developing the Regional ITS Architecture for Atlanta included several key steps:

- Preparing an inventory of planned and existing systems in the Region;
- Identifying needs in the Region that could be addressed by ITS deployment or integration;
- Customizing and prioritizing market packages to address the specific needs and services identified by stakeholders;
- Developing interconnects and interfaces for system elements to map out data flows and agency links;
- Preparing an operational concept to illustrate how the systems, components, and agencies will be integrated and function as a result of the architecture framework;
- Identifying high-level functional requirements;
- Identifying standards that could be applicable to the Atlanta Region; and
- Outlining potential agreements that would be needed to facilitate information or resource sharing as a result of ITS implementation.

### Inventory and Needs in the Region

The Atlanta Regional ITS Architecture began with a project kick-off meeting in November of 2002. At that meeting, stakeholders provided information about existing and planned ITS elements in the Region. A diverse range of needs were identified by stakeholders who attended. The highest priority needs focused on improving traveler information (particularly during hazardous weather and for closures of major routes), incident management during storms and winter weather, and enhancing coordination and communication among west Texas TxDOT Districts. The inventory of planned and existing ITS infrastructure provided the basis for the architecture development. Needs that could be addressed by ITS technologies guided the selection of market packages, data flows, and integration requirements.

The needs identified by the Atlanta Region stakeholders were categorized into functional areas, and are shown in **Table 1**.



**Table 1 – Atlanta Region: Summary of ITS Needs**

**Atlanta Region**  
**Summary of ITS Needs**  
**Atlanta Regional ITS Architecture and Deployment Plan Kick-Off Meeting**  
**November 19, 2002**

**Travel and Traffic Management Needs**

- Need low water crossing and underpass flood detection
- Need railroad notification/blocked roadway detection
- Need improved emergency response coordination
- Need joint operations between Texas and Arkansas for Texarkana TMC or TOC
- Need improved coordination and planning for high school football/special event traffic
- Need coordination with other TXDOT Districts, Arkansas, Louisiana for incident management and roadway closings
- Need improved planning for accommodation of hurricane evacuees from Louisiana and Southeast Texas
- Need VMS on I-30, I-49 and the planned loop
- Need weather data collection

**Public Transportation Management Needs**

- Need Computer Aided Dispatch – ATCOG
- Need Transit Operations Center – ATCOG
- Need Automated Vehicle Location – ATCOG, T Line
- Need Mobile Data Terminals – ATCOG
- Need On-Board Video Security – ATCOG, T Line
- Need signal preemption – T Line
- Need improved transit traveler information – kiosks at transfer stations

**Electronic Payment Needs**

None Identified

**Commercial Vehicle Operations Needs**

None Identified

**Emergency Management Needs**

- Need automated vehicle location for emergency vehicles
- Need signal preemption for emergency vehicles
- Need additional VMS for Amber Alerts
- Need to improve DPS communication and information dissemination coordination with TXDOT for incident management

**Advanced Vehicle Safety System Needs**

None Identified

**Information Management Needs (Data Archiving)**

None Identified

**Maintenance and Construction Management Needs**

None Identified

## Market Packages

A 2-Day ITS Architecture Workshop was held in Atlanta in January 2003. At this workshop, stakeholders were provided with architecture training that included background information about the National ITS Architecture, the purpose and benefits of a regional ITS architecture, and the process that would be used to develop the Atlanta Regional ITS Architecture.

The next step in developing the Atlanta Regional ITS Architecture was to identify the services that would be needed to address the stakeholder needs. In the National ITS Architecture, services are referred to as market packages. Market packages may include several stakeholders and elements that work together to provide a service in the Region. Examples of market packages from the National ITS Architecture include Network Surveillance, Traffic Information Dissemination, and Transit Vehicle Tracking. There are currently a total of 75 market packages identified in the National ITS Architecture.

At the 2-Day ITS Architecture Workshop, stakeholders selected the market packages that corresponded to the desired services and functions identified for the Region, and then customized these market packages. They included services and functions such as Network Surveillance, Road Weather Data Collection, and Emergency Response as well as market packages to address coordination needs, including an Incident Management System and Regional Traffic Control and Coordination. Because market packages are groups of services and functions, they can be deployed incrementally and over time. Of the 75 market packages in the National ITS Architecture, stakeholders identified 37 as being applicable to the Atlanta Region.

## Interconnects, Interfaces, and Standards

Stakeholders also began the process of mapping existing and planned ITS elements in Atlanta to the subsystems in the National ITS Architecture. These elements included agencies, systems, and essentially all of the ITS components in the Region. Subsystems are the highest level building blocks of the physical architecture, and the National ITS Architecture groups them into four major classes: Centers, Roadside, Vehicles, and Travelers. This mapping resulted in an interconnect diagram for the Atlanta Region, which is shown in **Figure 3** on the following page. This architecture diagram, also referred to as the “sausage diagram” shows the relationship of existing, planned, and future systems in the Atlanta Region.

The market packages in the National ITS Architecture were customized to reflect the unique systems, subsystems, and terminators in the Atlanta Region. Each market package was shown graphically, with the market package name, Atlanta specific element, and the unique agency and system identifiers within the subsystems and terminators.

**Figure 4** is an example of an ATMS market package for Network Surveillance that has been customized for the Atlanta Region. This market package shows three subsystems, Traffic Management, Roadway, and Information Service Provider, and the associated entities (TxDOT Atlanta District TMC/Office, TxDOT Atlanta District CCTV, etc.). Data flows between the subsystems and the terminators indicate what information is being shared. The solid data flow lines in this market package indicate existing information flows and the dashed lines indicate planned or future flows. All of the Atlanta Region market package diagrams are included in the Regional ITS Architecture report.

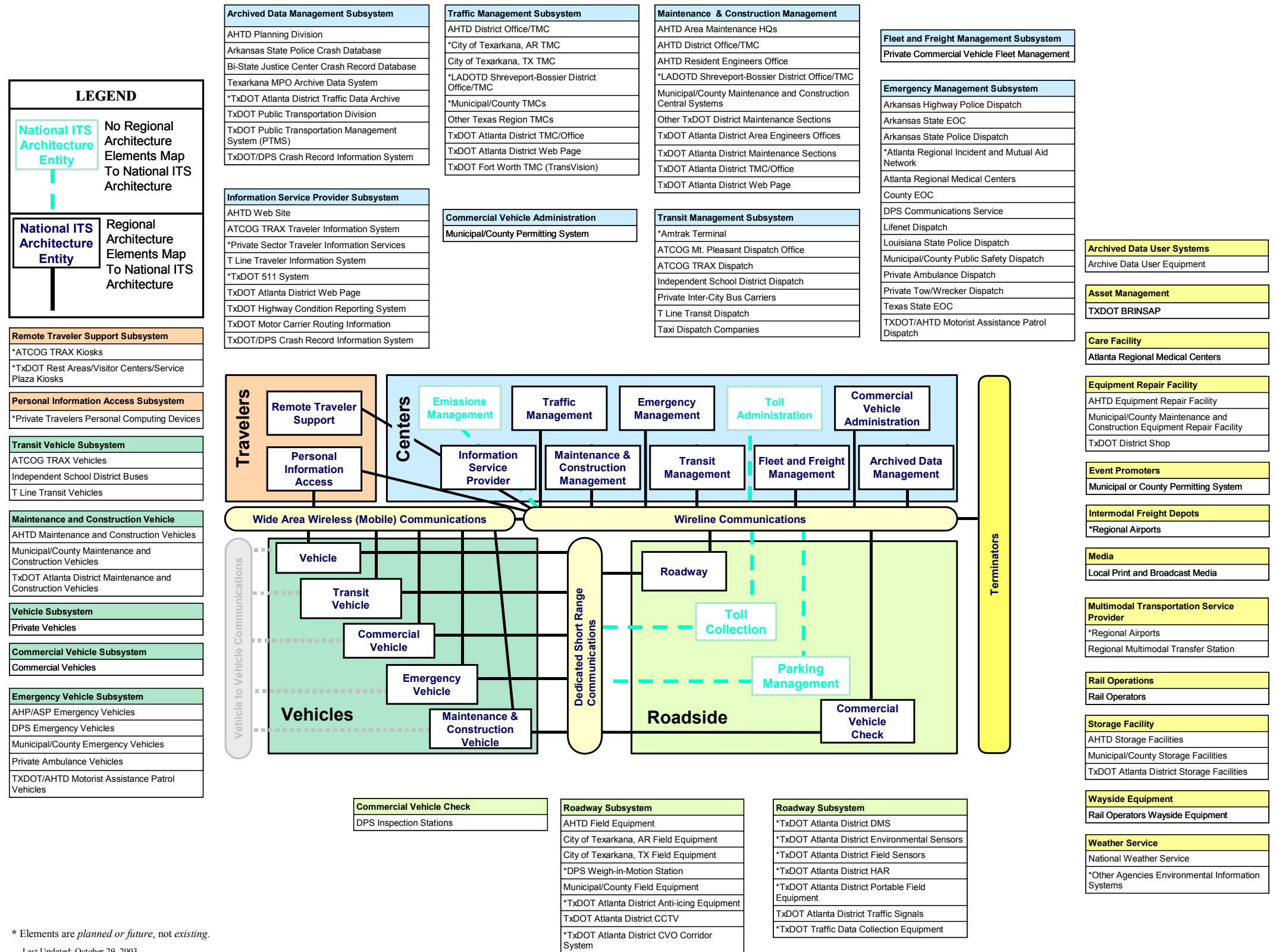

\* Elements are *planned or future*, not existing.  
 Last Updated: October 29, 2003

**Figure 3 – Atlanta Regional System Interconnect Diagram**

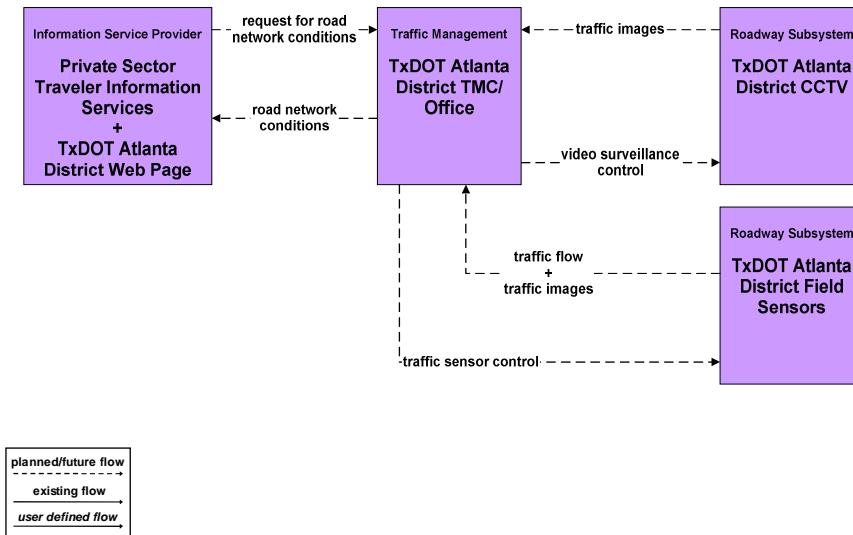

**Figure 4 – TxDOT Atlanta District TMC Network Surveillance Customized Market Package**

More detailed interfaces were developed which identified the connectivity between the systems and elements. Each element identified in the ITS architecture for the Atlanta Region was mapped to the other elements that it must interface with. These interfaces were further defined by architecture data flows between individual elements that specify the information to be exchanged. The data flows include requests for information, alerts and messages, status requests, confirmations, and other information requirements.

While it is important to identify the various systems and stakeholders as part of a regional ITS, a primary purpose of the architecture is to identify the connectivity between transportation systems in the Atlanta Region. There are 100 different elements identified as part of the Atlanta Regional ITS Architecture. These elements include local and state traffic management/operations centers, transit vehicles, dispatch systems, emergency management agencies, and others – essentially, all of the existing and planned physical components that contribute to a Regional ITS. Interfaces have been identified for each element in the Atlanta Regional ITS Architecture, and each element has been mapped to those other elements with which it must interface.

An example of one of the system interfaces is included as **Figure 5**. This graphic shows the TxDOT Atlanta District traffic signals and the existing and planned interfaces with other elements throughout the Region. These interfaces are shown as existing, planned, or future. Interfaces defined as planned have funding identified, while future interfaces are desired by stakeholders but funding has not yet been identified.

Architecture flows between the subsystems and terminators define the specific information (data) that is exchanged between subsystems and terminators. Each architecture flow has one or more data flows that specify what information is exchanged and the direction of the exchange.

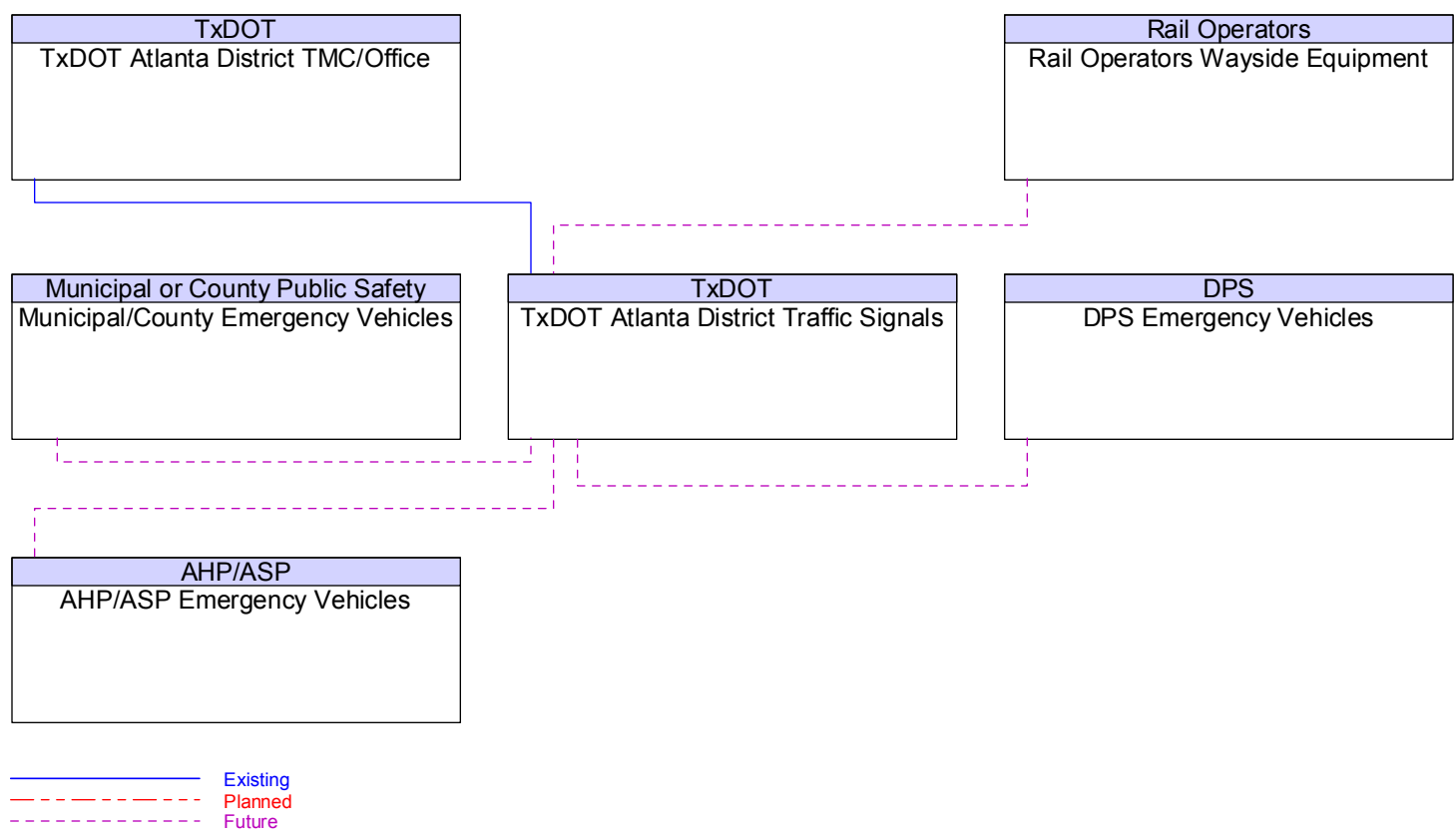

**Figure 5 – TxDOT Atlanta District Traffic Signals Interfaces**

An example of the architecture flows between two elements is shown in **Figure 6**. In this interface, the flows between the TxDOT Atlanta District TMC and other Texas Region TMCs show information that must go from the Atlanta District TMC to other Texas TMCs, as well as information that the TMC needs from devices. Similar to the interfaces, architecture flows also are defined as existing, planned, or future. All of the architecture flows between elements have been included on the project website.

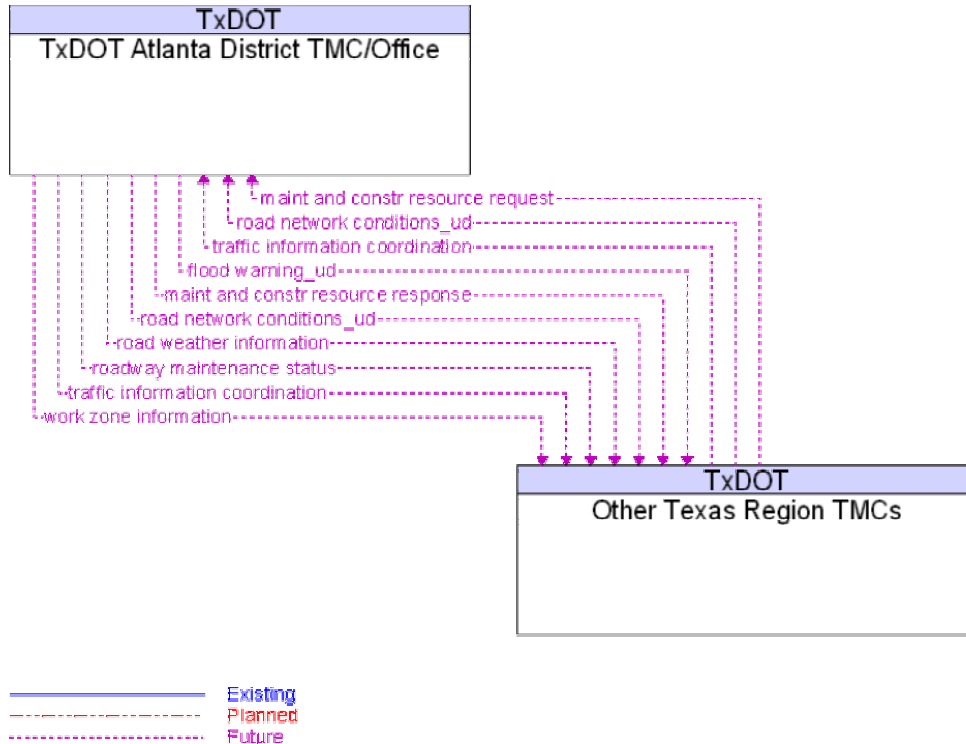

**Figure 6 – TxDOT Atlanta District TMC/Office to Other Texas Region TMCs Architecture Flows**

With the required interfaces and interconnections identified, standards that could potentially be applied to the Atlanta Region were identified. Standards are an important tool that will allow efficient implementation of the elements in the Atlanta Regional ITS Architecture over time. They facilitate deployment of interoperable systems at local, regional, and national levels without impeding innovation as technology advances, vendors change, and as new approaches evolve.

**Operational Concept and Scenarios**

An operational concept for the Atlanta Region was developed as part of the architecture process to illustrate how systems, components, and agencies will be integrated and function as a result of the framework provided by the Regional ITS Architecture. For the Atlanta Region, two concepts were illustrated. The first was a road construction project along I-30 that required long term lane closures. The operational concept shows through ITS deployment, emergency response, agency connectivity and information sharing, and traveler information tools, that agencies are able to work together and benefit from the technologies and systems in place to proactively manage the Region’s transportation system. The second concept illustrates a sequence of events during a

major winter storm and how TxDOT, emergency services, public safety, and other key agencies can put pre-determined response and diversion strategies into effect, as well as utilize technology and communications infrastructure, to respond effectively and increase motorist safety during hazardous winter weather.

## Agreements

Interfaces and data flows among public and private entities in the Atlanta Region will require agreements among agencies that establish parameters for sharing agency information to support traffic and incident management, provide traveler information, and perform other functions identified in the Regional ITS Architecture. Recommended projects will result in systems and interfaces that will require inter-agency agreements, both public and private, to facilitate the exchange of information.

Currently, there are no formal agreements in place in the Atlanta Region. Stakeholders indicated that while there is a high degree of cooperation among agencies, there hasn't been a need for formal agreements to facilitate multi-jurisdictional resource sharing, cooperation, or mutual aid. With the implementation of ITS technologies, integration of systems from one or more agencies, and the anticipated level of information exchange identified in the architecture, it is likely that more formal agreements will be needed.

The following is a list of potential agreements for the Atlanta Region based on the interfaces identified in the Regional ITS Architecture and recommended ITS projects in the Deployment Plan:

- Data sharing and usage agreements among public agencies;
- Data sharing and usage agreements among public and private media and information service providers;
- Shared video monitoring agreements between TxDOT and public safety agencies; and
- Mutual aid agreements among public sector agencies, primarily fire, police, emergency services, DPS, and TxDOT.

It is important to note that as ITS services and systems are implemented in the Region, part of the planning and review process for those projects should include a review of potential agreements that would be needed for implementation or operations.

## ITS Architecture Documentation

The Regional ITS Architecture for the Atlanta Region is documented in a final report. Stakeholders were brought together to review the Regional ITS Architecture and provide feedback. The final report was not prepared until after completion of the Atlanta Regional ITS Deployment Plan, to allow for modifications based on information and input received for the ITS Deployment Plan recommendations.

A website with all of the Regional ITS Architectures also was maintained. The website allowed stakeholders to review the architecture and provide comments directly to the project team through the website. At the time this report was published, the Atlanta Regional ITS Architecture website was being hosted at [www.consystem.com](http://www.consystem.com). The site can be accessed by selecting the link to Texas, and then the link to Atlanta. TxDOT plans to permanently host the site in the future at [www.dot.state.tx.us/trf/its](http://www.dot.state.tx.us/trf/its).



## ATLANTA REGIONAL ITS DEPLOYMENT PLAN

Although development of an ITS deployment plan was not required by the FHWA Final Rule for the architecture, the Final Rule does request a sequence of projects required for implementation. Capitalizing on the momentum and interagency dialogue established during the development of the Atlanta Regional ITS Architecture, TxDOT chose to expand on the project sequence requirement to develop a formal ITS deployment plan for the Region.

The Atlanta Regional ITS Architecture provided the framework and prioritized the key functions and services desired by stakeholders in the Region. The Atlanta ITS Deployment Plan builds on the architecture by prioritizing market packages, outlining specific ITS project recommendations and strategies for the Region, and identifying deployment timeframes so that the recommended projects and strategies can be implemented over time. Agency responsibilities for implementing and operating the systems also are a key component of the ITS Deployment Plan.

### Prioritized Market Packages

Market packages for the Atlanta Region previously identified as part of the architecture were categorized into high, medium, and low priorities by stakeholders. The market package prioritization was a key factor in developing recommendations for ITS deployment and integration in the Atlanta Region. These priorities identified the key needs and services that are desired in the Region, as well as the interfaces that need to be established to provide integrated functionality and establish communication between elements.

It is important to note that the high, medium, and low priorities were not directly related to anticipated deployment timeframes (such as 5, 10, or 20 year deployment horizon). For example, a market package can be a high priority, but because of funding or prerequisite project requirements, it might not be feasible for deployment for several years. Maturity and availability of technology was another factor for prioritizing the market packages. Because market packages often represent groups of technologies or services to deliver a particular functionality, certain components of the market package could be identified as a high priority or existing capability, while other components would have a lower priority. Other considerations included whether or not the market package was better suited for deployment and operations by the private sector rather than public agencies in the Region.

**Table 2** shows the prioritization of the selected market packages for the Atlanta Region. The majority of these market packages fall into the high priority category. This category also includes market packages (or portions of market packages) that are already deployed in the Atlanta Region, such as network surveillance, surface street control, and traffic information dissemination.

**Table 2 – Summary of Prioritized Market Packages for the Atlanta Region**

High Priority	Medium Priority	Low Priority
<ul style="list-style-type: none"> <li>▪ Network Surveillance</li> <li>▪ Surface Street Control</li> <li>▪ Traffic Information Dissemination</li> <li>▪ Regional Traffic Control</li> <li>▪ Incident Management System</li> <li>▪ Standard Railroad Grade Crossing</li> <li>▪ Advanced Railroad Grade Crossing</li> <li>▪ Railroad Operations Coordination</li> <li>▪ Road Weather Data Collection</li> <li>▪ Weather Information Processing and Distribution</li> <li>▪ Maintenance and Construction Activity Coordination</li> <li>▪ Transit Vehicle Tracking</li> <li>▪ Transit Fixed-Route Operations</li> <li>▪ Demand Response Transit Operations</li> <li>▪ Transit Traveler Information</li> <li>▪ Broadcast Traveler Information</li> <li>▪ Emergency Response</li> <li>▪ ITS Data Mart</li> </ul>	<ul style="list-style-type: none"> <li>▪ Roadway Automated Treatment</li> <li>▪ Winter Maintenance</li> <li>▪ Work Zone Management</li> <li>▪ Transit Security</li> <li>▪ Weigh-in-Motion</li> <li>▪ HAZMAT Management</li> <li>▪ Emergency Routing</li> <li>▪ Roadway Service Patrols</li> <li>▪ ITS Data Warehouse</li> <li>▪ ITS Virtual Data Warehouse</li> </ul>	<ul style="list-style-type: none"> <li>▪ Probe Surveillance</li> <li>▪ Maintenance and Construction Vehicle Tracking</li> <li>▪ Maintenance and Construction Vehicle Maintenance</li> <li>▪ Roadway Maintenance and Construction</li> <li>▪ Work Zone Safety Monitoring</li> <li>▪ Transit Maintenance</li> <li>▪ Multi-modal Coordination</li> <li>▪ CV Administrative Processes</li> <li>▪ ISP Based Route Guidance</li> </ul>

Each of the prioritized market packages was assessed from the perspective of deployment status (which components, if any, were already existing in the Region), as well as any planned or additional new needs to bring the market package to the desired level of functionality in the Atlanta Region. Each market package analysis included:

- A brief definition of the market package (modified from the National ITS Architecture definitions);
- Any infrastructure or components from that market package that is already existing in the Atlanta Region;
- Agencies currently operating or maintaining systems that apply to that market package;

- Planned projects that will address some or all of the services that are contained in the market package; and
- Any additional needs to bring the market package to the desired level of deployment or functionality.

### ITS Project Recommendations for the Atlanta Region

Using the needs, market package priorities, and any planned projects identified by the stakeholders during the architecture process, a list of recommended ITS projects for the Atlanta Region was developed. These projects were refined and additions and deletions were made by the Regional stakeholders at the ITS Deployment Plan Workshop in February 2003.

Recommended ITS projects for the Atlanta Region were categorized into short-, medium-, and long-term timeframes for programming in the 5, 10, and 20 year horizons. This was done based on current status if the project had previously been identified and planned by the Region, market package priority, and dependency on other project completions. The majority of the short term or 5-year recommendations serve as “foundation” projects to implement basic functionality, infrastructure, and interfaces, with the intent of continuing to build out those foundation projects over the 10 and 20 year timeframes. Most projects for the Atlanta Region are infrastructure based; however, there are some recommendations that focus more on institutional practices and interconnectivity to enhance coordination and communications.

Each recommended project for the Atlanta Region was included in a short-, medium-, or long-term table. These tables provided the name of the project, primary operating/implementing agency, a planning level estimate of probable cost, an indication of whether or not funding had been identified for that specific project, and an estimated project duration. Following each table, detailed descriptions of each project were developed, which also included associated market packages and any pre-requisite project requirements.

**Table 3** summarizes the ITS projects recommended for the Atlanta Region. This summary is divided into the major program areas and subdivided by timeframe. As can be seen from this summary, the majority of the project recommendations focus on the Travel and Traffic Management category, which would implement surface street traffic management, traveler information, and inter-agency coordination elements.

**Table 3 – Recommended ITS Projects for the Atlanta Region**

Project Time Frame	Project Name	Funding Identified (Funding Agency if Applicable)
<b><i>Travel and Traffic Management</i></b>		
Short Term Projects 5-year Horizon	TxDOT Atlanta TMC Expansion and ATMS Implementation	No
	TxDOT DMS on I-20 and I-30	No
	AHTD DMS on I-30	No
	TxDOT CCTV Cameras on I-30	No
	TxDOT/AHTD DMS on Loop	No
	TxDOT/AHTD CCTV on Loop	No
	TxDOT Closed Loop Signal System Expansion and VIVDS Upgrade Phase 1	Yes (TxDOT)
	TxDOT Fog Detection in Titus County	No
	TxDOT Changeable Message Speed Display Signs	No
	TxDOT Center to Center Communications (Statewide)	Yes (TxDOT Statewide)
	City of Texarkana, TX TOC	No
	City of Texarkana, TX TOC/TxDOT Atlanta TMC Connection	No
	City of Texarkana, TX Closed Loop Signal System Expansion Phase 1	No
	City of Texarkana, TX Railroad Advance Warning	No
	AHTD District TMC/TxDOT Atlanta TMC Communications Connection	No
Mid Term Projects 10-year Horizon	TxDOT Closed Loop Signal System Expansion and VIVDS Upgrade Phase 2	No
	Regional 511 Advanced Traveler Information System Server	No
	Media Liaison and Coordination	N/A
	City of Texarkana, TX/City of Texarkana, AR Joint Operations TOC	No
	City of Texarkana, TX Closed Loop Signal System Expansion Phase 2	No
	City of Texarkana, AR Closed Loop Signal System Phase 1	No
	City of Texarkana, TX VIVDS Expansion Phase 2	No
	City of Texarkana, AR VIVDS Phase 1	No
	Other Cities/Counties/TxDOT Atlanta TMC Communications Connection	No
Long Term Projects 20-year Horizon	TxDOT Closed Loop Signal System Expansion and VIVDS Upgrade Phase 3	No
	TxDOT/AHTD DMS on I-49	No
	TxDOT/AHTD DMS on I-69	No
	TxDOT CCTV Cameras on I-49	No

**Table 3 – Recommended ITS Projects for the Atlanta Region (continued)**

<b>Project Time Frame</b>	<b>Project Name</b>	<b>Funding Identified (Funding Agency if Applicable)</b>
<b><i>Emergency Management</i></b>		
Short Term Projects 5-year Horizon	City of Texarkana, TX Emergency Vehicle AVL	No
	City of Marshall Emergency Vehicle AVL	No
	HAZMAT Management Plans	No
Mid Term Projects 10-year Horizon	DPS/TxDOT TMC Communications Connection	No
	TxDOT Emergency Vehicle Signal Preemption	No
	City of Texarkana, TX Emergency Vehicle Signal Preemption	No
	City of Texarkana, AR Emergency Vehicle Signal Preemption	No
	City of Texarkana, AR Emergency Vehicle AVL	No
	City of Marshall Fire/EMS Signal Preemption	No
Long Term Projects 20-year Horizon	City of Atlanta Emergency Vehicle AVL	No
	Other Emergency Management/TxDOT TMC Connection	No
	DPS MDTs	No
	AHP MDTs	No
	Other Cities/Counties Emergency Vehicle Signal Preemption	No
<b><i>Maintenance and Construction Management</i></b>		
Short Term Projects 5-year Horizon	TxDOT Additional RWIS Sites	No
	TxDOT Additional Portable DMS	No
	TxDOT Portable Speed Trailers	No
	TxDOT HCRS Enhancements	Yes (TxDOT Statewide)
Mid Term Projects 10-year Horizon	TxDOT Flood Detection	No
	City of Marshall Flood Detection	No
Long Term Projects 20-year Horizon	TxDOT Ice Detection and Anti-Icing Equipment on Bridges	No
<b><i>Public Transportation Management</i></b>		
Short Term Projects 5-year Horizon	ATCOG Transit Operations Center with CAD System	No
	ATCOG Communications System Upgrade	No
	T Line On Board Security Cameras	No

**Table 3 – Recommended ITS Projects for the Atlanta Region (continued)**

Project Time Frame	Project Name	Funding Identified (Funding Agency if Applicable)
<b><i>Public Transportation Management (continued)</i></b>		
Mid Term Projects 10-year Horizon	T Line Dispatch/TxDOT TMC/AHTD District TMC Communications Connection	No
	T Line AVL	No
	ATCOG AVL	No
	ATCOG TOC/TxDOT TMC Communications Connection	No
	ATCOG On Board Security Cameras	No
	ATCOG MDTs	No
Long Term Projects 20-year Horizon	ATCOG Web-based Ride Scheduling	No
	T Line Signal Priority for Buses	No
	ATCOG Transit Traveler Information Kiosks	No
<b><i>Information Management</i></b>		
Short Term Projects 5-year Horizon	Texarkana MPO Data Warehouse	No
Mid Term Projects 10-year Horizon	No Mid Term Projects were identified	No
Long Term Projects 20-year Horizon	Texarkana MPO Virtual Data Warehouse	No

## **MAINTAINING THE REGIONAL ITS ARCHITECTURE AND DEPLOYMENT PLAN**

With the substantial amount of effort invested by stakeholders in the Atlanta Region to develop both the Regional ITS Architecture and the ITS Deployment Plan, developing a strategy for maintaining these important tools was a key component of the process.

New market packages are added to the National ITS Architecture every few years, and with the increasing emphasis on homeland security issues, it is envisioned that there will be additional market packages focused on addressing homeland security and emergency management. New federal initiatives, such as Amber Alert and 511, could also generate new or updated categories of market packages within the National ITS Architecture. Atlanta stakeholders agreed that it would be beneficial to review any modifications to the National ITS Architecture as well as any USDOT/FHWA guidance on an as-needed basis, and identify any additions or modifications that should be considered for the Atlanta Regional ITS Architecture.

As deployment and integration progress in the Atlanta Region, stakeholders that were not involved in developing the initial architecture and deployment plan might have a more vested interest or role in ITS in the Region. Stakeholders agreed that new or additional stakeholders also should be added to future review discussions if appropriate.

At the Comment Resolution Meeting held in Atlanta in September 2003, stakeholders agreed that both the Regional ITS Architecture and the ITS Deployment Plan will need to be periodically updated in order to reflect current deployment status as well as re-evaluate priorities. A two-year timeframe was selected by the stakeholders for this update to correspond with the Transportation Improvement Plan (TIP) updates. The TxDOT Atlanta District was identified as the agency that should take the lead in maintaining and updating the Region's ITS Architecture and Deployment Plan, with support and input from other stakeholders in the Region.





## MEMORANDUM OF UNDERSTANDING

As a final step in the development of the Atlanta Regional ITS Architecture and Deployment Plan, a Memorandum of Understanding (MOU) was prepared for the participating stakeholder agencies. The MOU was developed for stakeholders to acknowledge their participation and approval of the plan, and pledge their support in the implementation and operation of intelligent transportation systems in the Atlanta Region. Also included in the MOU was a pledge to provide TxDOT with the information necessary to maintain the Regional ITS Architecture and ITS Deployment Plan.

Although there were a number of other very important stakeholders participating in the project, those stakeholders that were asked to sign the MOU represented agencies that will have the greatest impact in the Region in terms of ITS deployments and system operations. TxDOT has primary responsibility for the majority of transportation infrastructure in the Region, and as a result, the majority of the stakeholders that participated represented various groups within TxDOT, including maintenance, traffic operations, public transportation, Area Offices, and neighboring Districts. Stakeholder agencies that were asked to sign the MOU for the Atlanta Regional ITS Architecture and Deployment Plan included the following:

- Arkansas Highway and Transportation Department;
- Ark-Tex Council of Governments;
- City of Marshall;
- City of Texarkana, Texas;
- City of Texarkana MPO;
- Louisiana Department of Transportation and Development;
- Texarkana Urban Transit District;
- Texas Department of Public Safety; and
- Texas Department of Transportation.